

# VocoPro®

PROFESSIONAL VOCAL SYSTEMS™

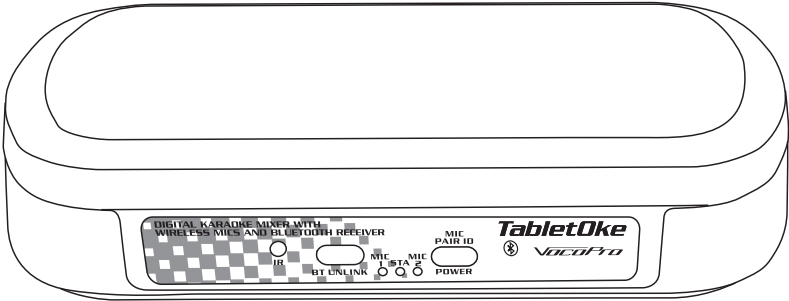
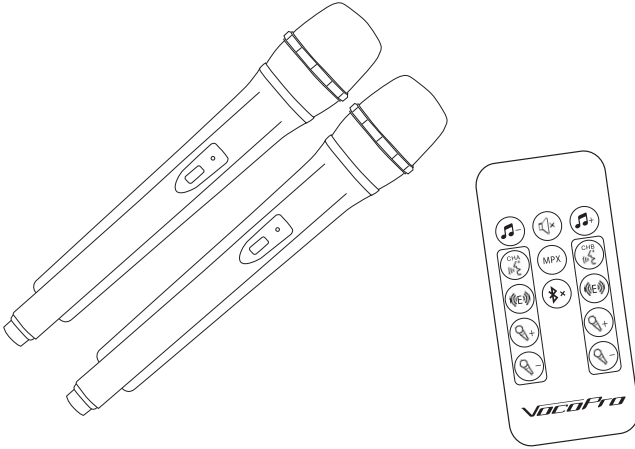

## TabletOke

Digital Karaoke Mixer with Wireless Mics and Bluetooth Receiver

o w n e r ' s m a n u a l



# Table of Contents

Safety Instructions . . . . .	4
FCC Information . . . . .	5
Welcome. . . . .	6
Listening for a Lifetime . . . . .	7
Getting Started . . . . .	8
Getting Connected . . . . .	9
Basic Operations . . . . .	10
Pairing the Microphones . . . . .	12
Pairing A Bluetooth Device . . . . .	13
Commonly Asked Questions . . . . .	14

# Safety Instructions



## CAUTION RISK OF SHOCK



CAUTION: To reduce the risk of electric shock, do not remove cover (or back). No user-serviceable parts inside. Only refer servicing to qualified service personnel.



## Explanation of Graphical Symbols

The lightning flash & arrowhead symbol, within an equilateral triangle, is intended to alert you to the presence of danger.

The exclamation point within an equilateral triangle is intended to alert you to the presence of important operating and servicing instructions.

## WARNING

To reduce the risk of fire or electric shock, do not expose this unit to rain or moisture.

- 1. Read Instructions** - All the safety and operating instructions should be read before the appliance is operated.
- 2. Retain Instructions** - The safety and operating instructions should be retained for future reference.
- 3. Heed Warnings** - All warnings on the appliance and in the operating instructions should be adhered to.
- 4. Follow Instructions** - All operating and use instructions should be followed.
- 5. Attachments** - Do not use attachments not recommended by the product manufacturer as they may cause hazards.
- 6. Water and Moisture** - Do not use this unit near water. For example, near a bathtub or in a wet basement and the like.
- 7. Carts and Stands** - The appliance should be used only with a cart or stand that is recommended by the manufacturer.
- 7 A.** An appliance and cart combination should be moved with care. Quick stops, excessive force, and uneven surfaces may cause an overturn. 
- 8. Ventilation** - The appliance should be situated so its location does not interfere with its proper ventilation. For example, the appliance should not be situated on a bed, sofa, rug, or similar surface that may block the ventilation slots.
- 9. Heat** - The appliance should be situated away from heat sources such as radiators, heat registers, stoves, or other appliances (including amplifiers) that produce heat.
- 10. Power Sources** - The appliance should be connected to a power supply only of the type described in the operating instructions or as marked on the appliance.
- 11. Grounding or Polarization** - Precautions should be taken so that the grounding or polarization means of an appliance is not defeated.
- 12. Power-Cord Protection** - Power-supply cords should be routed so that they are not likely to be walked on or pinched by items placed upon or against them, paying particular attention to cords at plugs, convenience receptacles, and the point where they exit from the appliance.
- 13. Cleaning** - Unplug this unit from the wall outlet before cleaning. Do not use liquid cleaners or aerosol cleaners. Use a damp cloth for cleaning.
- 14. Power lines** - An outdoor antenna should be located away from power lines.
- 15. Nonuse Periods** - The power cord of the appliance should be unplugged from the outlet when left unused for a long period of time.
- 16. Object and Liquid Entry** - Care should be taken so that objects do not fall and liquids are not spilled into the enclosure through openings.
- 17. Damage Requiring Service** - The appliance should be serviced by qualified service personnel when:
  - A. The power supply cord or plug has been damaged; or
  - B. Objects have fallen into the appliance; or
  - C. The appliance has been exposed to rain; or
  - D. The appliance does not appear to operate normally or exhibits a marked change in performance; or
  - E. The appliance has been dropped, or the enclosure damaged.
- 18. Servicing** - The user should not attempt to service the appliance beyond that described in the operating instructions. All other servicing should be referred to qualified service personnel.

### Note:

To CATV system installer's (U.S.A.): This reminder is provided to call the CATV system installer's attention to Article 820-40 of the NEC that provides guidelines for proper grounding and, in particular, specifies that the cable ground shall be connected as close to the point of cable entry as practical.

# FCC Information

**1. IMPORTANT NOTICE: DO NOT MODIFY THIS UNIT!** This product, when installed as indicated in the instructions contained in this manual, meets FCC requirements. Modifications not expressly approved by Vocopro may void your authority, granted by the FCC, to use this product.

**2. IMPORTANT:** When connecting this product to accessories and/or another product use only high quality shielded cables. Cable(s) supplied with this product **MUST** be used. Follow all installation instructions. Failure to follow instructions could void your FCC authorization to use this product in the U.S.A.

**3. NOTE:** This product has been tested and found to comply with the requirements listed in FCC Regulations, Part 15 for Class "B" digital devices. Compliance with these requirements provides a reasonable level of assurances that your use of this product in a residential environment will not result in harmful interference with other electronic devices. This equipment generates/uses radio frequencies and, if not installed and used according to the instructions found in the owner's manual, may cause interference harmful to the operation of other electronic devices. Compliance with FCC regulations does not guarantee that interference will not occur in all installations. If this product is found to be the source of interference, which can be determined by turning the unit "Off" and "On", please try to eliminate the problem by using one of the following measures:

Relocate either this product or the device that is being affected by the interference.

Use power outlets that are on different branch (circuit breaker or fuse) circuits or install AC line filter(s).

In the case of radio or TV interference, relocate/reorient the antenna. If the antenna lead-in is 300-ohm ribbon lead, change the lead-in to coaxial type cable.

If these corrective measures do not produce satisfactory results, please contact your local retailer authorized to distribute Vocopro products. If you can not locate the appropriate retailer, please contact Vocopro, 1728 Curtiss Court, La Verne, CA 91750.

## CAUTION

The apparatus is not disconnected from the AC power source so long as it is connected to the wall outlet, even if the apparatus itself is turned off. To fully ensure that the apparatus is indeed fully void of residual power, leave unit disconnected from the AC outlet for at least fifteen seconds.

## CAUTION:

### READ THIS BEFORE OPERATING YOUR UNIT

1. To ensure the finest performance, please read this manual carefully. Keep it in a safe place for future reference.
2. Install your unit in a cool, dry, clean place - away from windows, heat sources, and too much vibration, dust, moisture or cold. Avoid sources of hum (transformers, v motors). To prevent fire or electrical shock, do not expose to rain and water.
3. Do not operate the unit upside-down.
4. Never open the cabinet. If a foreign object drops into the set, contact your dealer.
5. Place the unit in a location with adequate air circulation. Do not interfere with its proper ventilation; this will cause the internal temperature to rise and may result in a failure.
6. Do not use force on switches, knobs or cords. When moving the unit, first turn the unit off. Then gently disconnect the power plug and the cords connecting to other equipment. Never pull the cord itself.
7. Do not attempt to clean the unit with chemical solvents: this might damage the finish. Use a clean, dry cloth.
8. Be sure to read the "Troubleshooting" section on common operating errors before concluding that your unit is faulty.
9. This unit consumes a fair amount of power even when the power switch is turned off. We recommend that you unplug the power cord from the wall outlet if the unit is not going to be used for a long time. This will save electricity and help prevent fire hazards. To disconnect the cord, pull it out by grasping the plug. Never pull the cord itself.
10. To prevent lightning damage, pull out the power cord and remove the antenna cable during an electrical storm.
11. The general digital signals may interfere with other equipment such as tuners or receivers. Move the system farther away from such equipment if interference is observed.

### Voltage Selector (General Model Only)

#### NOTE:

Please check the copyright laws in your country before recording from records, compact discs, radio, etc. Recording of copyrighted material may infringe copyright laws.

Be sure to position the voltage selector to match the voltage of your local power lines before installing the unit.

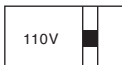

### CALIFORNIA PROP 65 WARNING

**WARNING:** This product contains chemicals known to the state of California to cause cancer and birth defects or other reproductive harm. (California law requires this warning to be given to customers in the State of California.)

For more information: [www.vocopro.com/prop65](http://www.vocopro.com/prop65)

## Welcome

And thank you for purchasing the **TabletOke** from VocoPro, your ultimate choice in Karaoke entertainment! With years of experience in the music entertainment business, VocoPro is a leading manufacturer of Karaoke equipment, and has been providing patrons of bars, churches, schools, clubs and individual consumers the opportunity to sound like a star with full-scale club models, in-home systems and mobile units. All our products offer solid performance and sound reliability, and to reinforce our commitment to customer satisfaction, we have customer service and technical support professionals ready to assist you with your needs. We have provided some contact information for you below.

### VocoPro

1728 Curtiss Court  
La Verne, CA 91750

**Toll Free: 800-678-5348**

TEL: 909-593-8893

FAX: 909-593-8890

### VocoPro Company Email Directory

#### Customer Service & General Information

info@vocopro.com

#### Tech Support

techsupport@vocopro.com

#### Remember Our Website

Be sure to visit the VocoPro website **www.vocopro.com** for the latest information on new products, packages and promos. And while you're there don't forget to check out our Club VocoPro for Karaoke news and events, chat rooms, club directories and even a KJ Service directory!

We look forward to hearing you sound like a PRO, with VocoPro, the singer's ultimate choice.

### FOR YOUR RECORDS

Please record the model number and serial number below, for easy reference, in case of loss or theft. These numbers are located on the rear panel of the unit. Space is also provided for other relevant information

**Model Number**

**Serial Number**

**Date of Purchase**

Place of Purchase

# Listening for A Lifetime

Selecting fine audio equipment such as the unit you've just purchased is only the start of your musical enjoyment. Now it's time to consider how you can maximize the fun and excitement your equipment offers. VocoPro and the Electronic Industries Association's Consumer Electronics Group want you to get the most out of your equipment by playing it at a safe level. One that lets the sound come through loud and clear without annoying blaring or distortion and, most importantly, without affecting your sensitive hearing.

Sound can be deceiving. Over time your hearing "comfort level" adapts to a higher volume of sound. So what sounds "normal" can actually be loud and harmful to your hearing. Guard against this by setting your equipment at a safe level BEFORE your hearing adapts.

To establish a safe level:

- Start your volume control at a low setting.
- Slowly increase the sound until you can hear it comfortably and clearly, and without distortion.

Once you have established a comfortable sound level:

- Set the dial and leave it there.
- Pay attention to the different levels in various recordings.

Taking a minute to do this now will help to prevent hearing damage or loss in the future. After all, we want you listening for a lifetime.

Used wisely, your new sound equipment will provide a lifetime of fun and enjoyment. Since hearing damage from loud noise is often undetectable until it is too late, this manufacturer and the Electronic Industries Association's Consumer Electronics Group recommend you avoid prolonged exposure to excessive noise. This list of sound levels is included for your protection.

## **Some common decibel ranges:**

Level	Example
<b>30</b>	Quiet library, Soft whispers
<b>40</b>	Living room, Refrigerator, Bedroom away from traffic
<b>50</b>	Light traffic, Normal Conversation
<b>60</b>	Air Conditioner at 20 ft., Sewing machine
<b>70</b>	Vacuum cleaner, Hair dryer, Noisy Restaurant
<b>80</b>	Average city traffic, Garbage disposals, Alarm clock at 2 ft.

## **The following noises can be dangerous under constant exposure:**

Level	Example
<b>90</b>	Subway, Motorcycle, Truck traffic, Lawn Mower
<b>100</b>	Garbage truck, Chainsaw, Pneumatics drill
<b>120</b>	Rock band concert in front of speakers
<b>140</b>	Gunshot blast, Jet plane
<b>180</b>	Rocket launching pad

-Information courtesy of the Deafness Research Foundation

# Getting Started

## WHAT'S IN THE BOX

- TabletOke
- (2) Wireless Microphones
- Remote Control
- USB Power Cord with Adapter
- 1/8"-to-RCA Cable
- 1/8" Stereo cable

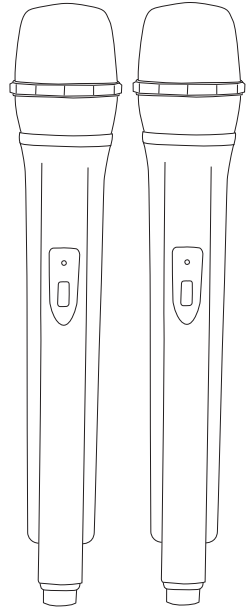
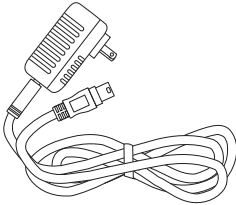
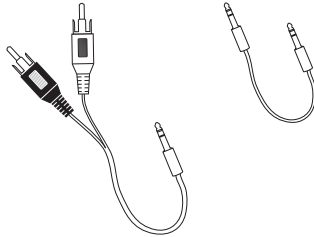
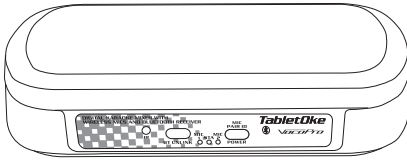



# Getting Connected

## CONNECTING TO AN AMPLIFIER

Connect the 1/8"-to-RCA cable from the Audio Mixed Output to desired amplifier.

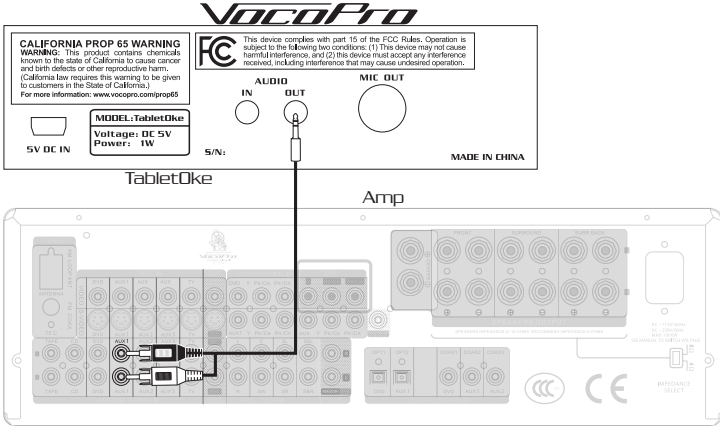

## CONNECTING TO POWERED SPEAKER

Connect the 1/8"-to-RCA cable from the Audio Mixed Out jack into an available RCA audio input on the powered speaker.

**Note:** Use the 1/4" Microphone Out to get the microphone signal only.

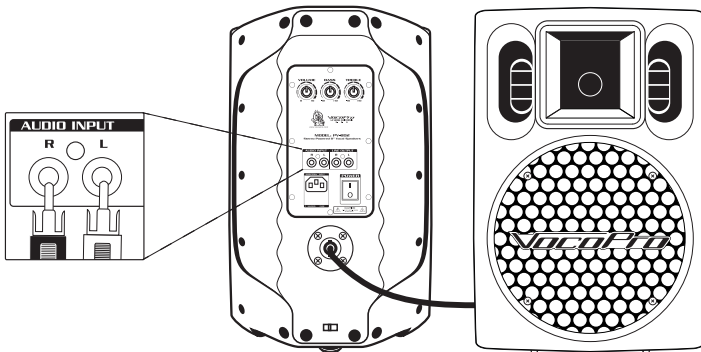

# Basic Operations

## FRONT PANEL

1. CH. A/B LEDs - Indicates connection status of each microphone.
2. Power Button/Pair ID - Turns receiver ON/OFF; toggles the Pairing Mode.
3. IR Sensor - Remote control sensor
4. Status - Flashes to confirm remote button selection.

**Note:** Please do NOT block IR Sensor

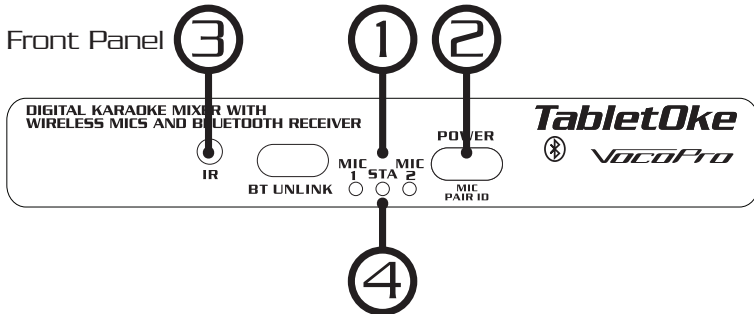

## REAR PANEL

1. Microphone Out - Provides microphone output only.
2. Audio Mixed Out - Provides both microphone and music output.
3. Audio In - Connect a music source that uses the 1/8" audio jack.
4. Power In - Power cord connects here. Any adapter will work if rated at 5V DC.

### Rear Panel

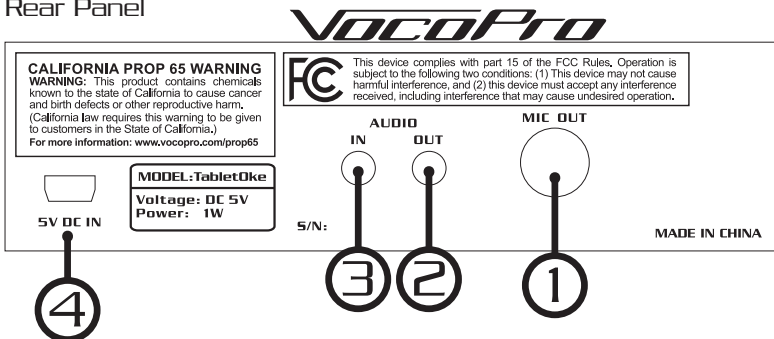

# Basic Operations

## REMOTE CONTROL

### MIC 1 (LEFT SIDE)

1. Volume +/- - Raises and lowers Mic 1 volume.
- 1a. Mic Echo - Toggles through Echo effect presets in Mic 1.
  - Low
  - Middle
  - High
  - Off
3. Bluetooth Disconnect - Terminates current Bluetooth connection.
4. MPX - Toggles between Left-Mono, Right-Mono, and Stereo.
5. Mic EQ - Toggle through Mic EQ presets.
  - Low-end (accentuates Bass frequencies)

Middle (accentuates Middle frequencies)

High-end (accentuates High frequencies)

6. Music Vol +/- - Raises and lowers Music volume.

7. Mute - Mutes all audio output; both Mic and Music.

### MIC 2 (RIGHT SIDE)

2. Volume +/- - Raises and lowers Mic 2 volume.
- 2a. Mic Echo - Toggles through Echo effect presets in Mic 2.
  - Low
  - Middle
  - High
  - Off

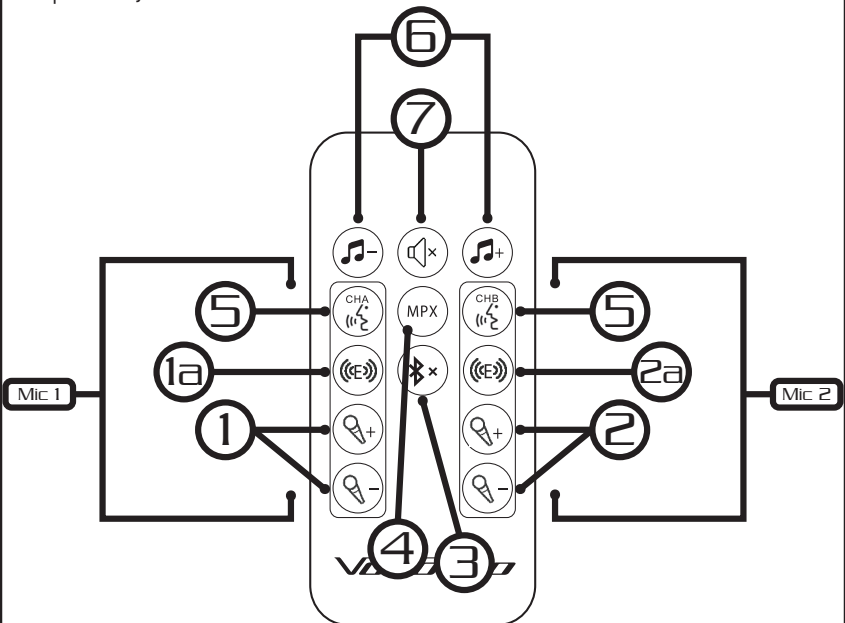

# Pairing the Microphones

If the Microphones experience signal loss or drop outs, the microphones should be resynced to the receiver. In doing so, the receiver will automatically change the operational frequency of each mic.

## FOLLOW THE STEPS BELOW TO RESYNC THE MICROPHONES WITH A NEW FREQUENCY CHANNEL.

1. Ensure the receiver and both microphones are powered off.
2. Power receiver on - Press power button once (1x).
3. Press and hold the Power/Pair ID button until both Mic channel LEDs are flashing rapidly.
4. When the Mic channel LEDs, Mic 1 & Mic 2, are flashing rapidly, turn on both handheld microphones one at a time to assign the channels.

**Note:** The channel indicator lights on the receiver will then flash and the receiver will power off. This is normal.

5. Power the receiver and both microphones back on and ensure that the Mic channel LEDs are solidly lit on the receiver; this indicates the microphones were paired successfully.

**Note:** The receiver **WILL** shut off when it pairs with a microphone, this is normal.

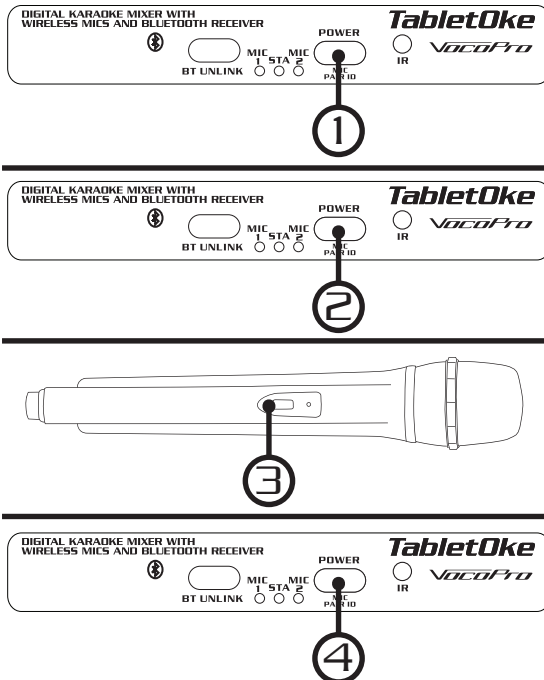

## Pairing A Bluetooth Device

1. Turn on the Bluetooth Function in the source player (i.e. smartphone, laptop, MP3 player).
2. On the Source Player, Scan for visible Bluetooth devices.
3. The TabletOke will show upon the list of visible devices, if within range.
4. Select TabletOke to connect.

**Note:** *TabletOke will only connect to A2DP enabled Bluetooth devices.*

5. Any audio from your source player will stream to the TabletOke.

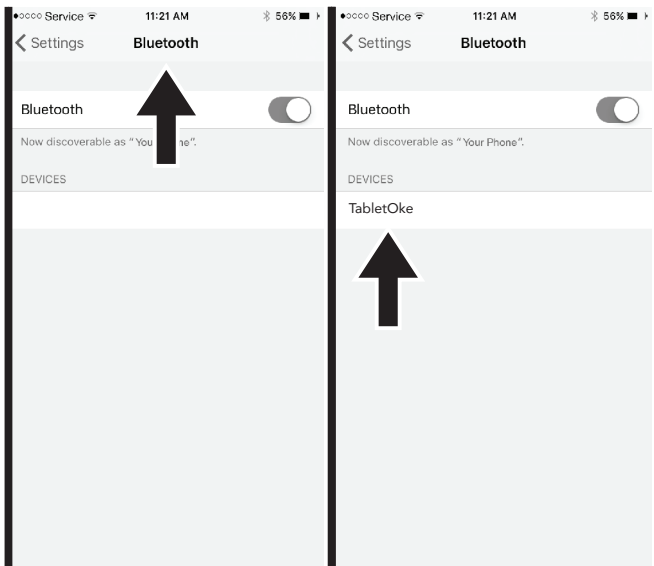

## Commonly Asked Questions

**Q. What is the range of the microphones?**

**A.** The maximum range is approximately 40ft.

**Q. How far will my device stay connected to the TabletOke?**

**A.** Bluetooth has a maximum range of 30ft.

**Q. What is A2DP?**

**A.** A2DP is the Bluetooth protocol that allows your phone/tablet/computer to send audio through Bluetooth the

TabletOke. If you have a smartphone, you likely have an A2DP enabled phone.

**Q. I lost my original power supply, what can I do?**

**A.** Any standard computer USB jack will power the TabletOke. You can also use any power adapter rated at 5V DC.

**Q. I'm missing some parts from my box. What can I do?**

**A.** Please call Vocopro regarding any missing or defective parts at 800-678-5348.

Notes

